



US010910129B1

(12) **United States Patent**
Munsell et al.

(10) **Patent No.:** US 10,910,129 B1
(45) **Date of Patent:** Feb. 2, 2021

(54) **METHOD OF MANUFACTURING A RODENT REPELLENT CABLE**

USPC 174/70 R
See application file for complete search history.

(71) Applicant: **STICK-IN-THE-MUD, LLC**, Chula Vista, CA (US)

(56) **References Cited**

(72) Inventors: **Clyde Stephan Munsell**, Chula Vista, CA (US); **James Dalgleish Reid**, San Diego, CA (US); **Richard William Hanawalt**, Ventura, CA (US)

U.S. PATENT DOCUMENTS

- 1,520,680 A * 12/1924 Abbott H01B 7/02
174/117 R
- 2,222,638 A * 11/1940 Szilard H01B 7/28
174/116
- 2,351,589 A * 6/1944 Abbott H01B 13/26
57/7
- 2,536,885 A * 1/1951 Olson H01B 7/18
156/54

(73) Assignee: **STICK-IN-THE-MUD, LLC**, Chula Vista, CA (US)

(Continued)

(*) Notice: Subject to any disclaimer, the term of this patent is extended or adjusted under 35 U.S.C. 154(b) by 0 days.

Primary Examiner — Timothy J Thompson
Assistant Examiner — Michael F McAllister
(74) *Attorney, Agent, or Firm* — US IP Attorneys, P.C.; Timothy Marc Shropshire

(21) Appl. No.: 17/039,806

(22) Filed: Sep. 30, 2020

Related U.S. Application Data

- (62) Division of application No. 16/669,341, filed on Oct. 30, 2019, now Pat. No. 10,839,983.
- (60) Provisional application No. 62/753,287, filed on Oct. 31, 2018.

(57) **ABSTRACT**

A rodent repellent cable includes a jacket, a transmission means for facilitating transmission of electrical current or data, and a repellent bonded to at least one component of the cable. A method of manufacturing the rodent repellent cable includes electrostatically bonding a repellent to one or more components of the cable and adding the jacket around the internal components of the cable. The repellent is preferably an olfactory stimulant configured to repel rodents. Prior to adding the jacket around the internal components, the method may also include wrapping, enclosing, or otherwise surrounding one or more of the transmission means with a separator and/or wrapping, enclosing, or otherwise surrounding an assembly of internal components with a sheath. Additionally, prior to adding the jacket around the internal components, an assembly of internal components may be passed through a cooling apparatus to cool the assembly to a pre-determined temperature.

- (51) **Int. Cl.**
A01N 31/06 (2006.01)
H01B 7/18 (2006.01)
H01B 13/22 (2006.01)
H01B 13/00 (2006.01)
G02B 6/44 (2006.01)
- (52) **U.S. Cl.**
CPC H01B 7/1805 (2013.01); A01N 31/06 (2013.01); G02B 6/4432 (2013.01); H01B 13/002 (2013.01); H01B 13/227 (2013.01)
- (58) **Field of Classification Search**
CPC .. H01B 7/1805; H01B 13/002; H01B 13/227; A01N 31/06; G02B 6/4432

17 Claims, 7 Drawing Sheets

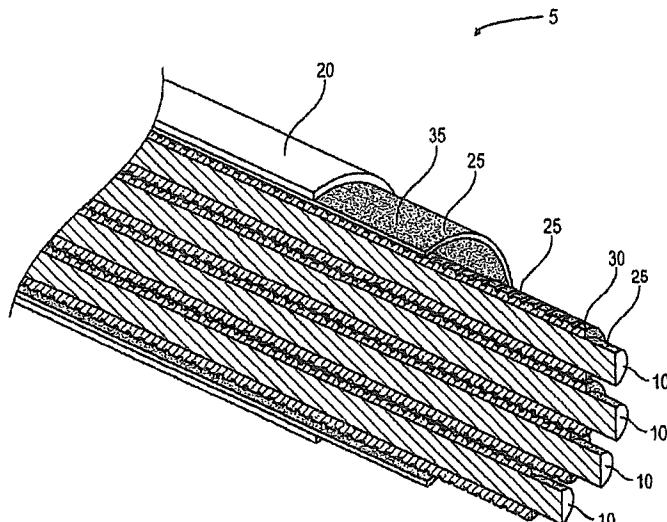

US 10,910,129 B1

Page 2

(56)

References Cited

U.S. PATENT DOCUMENTS

2,856,453 A *	10/1958	Shepp	H01B 7/041 174/116
4,171,463 A *	10/1979	Watkins	H01B 7/282 174/120 R
4,847,151 A *	7/1989	Ichiro	A01N 25/10 428/389
5,280,137 A *	1/1994	Ward	H01B 7/187 174/110 V
5,993,966 A *	11/1999	Johnson	D02G 3/44 424/412
7,287,489 B1 *	10/2007	O'Brien	A01K 15/02 119/712
8,734,819 B2 *	5/2014	Dussich, Jr.	A01N 65/28 424/403
8,940,767 B2 *	1/2015	Numata	A01N 37/18 514/321
9,271,486 B2 *	3/2016	Messina	A01N 65/28
10,100,180 B2 *	10/2018	Dussich	C08K 3/34
2010/0260872 A1 *	10/2010	Dussich, Jr.	A01N 65/22 424/742

* cited by examiner

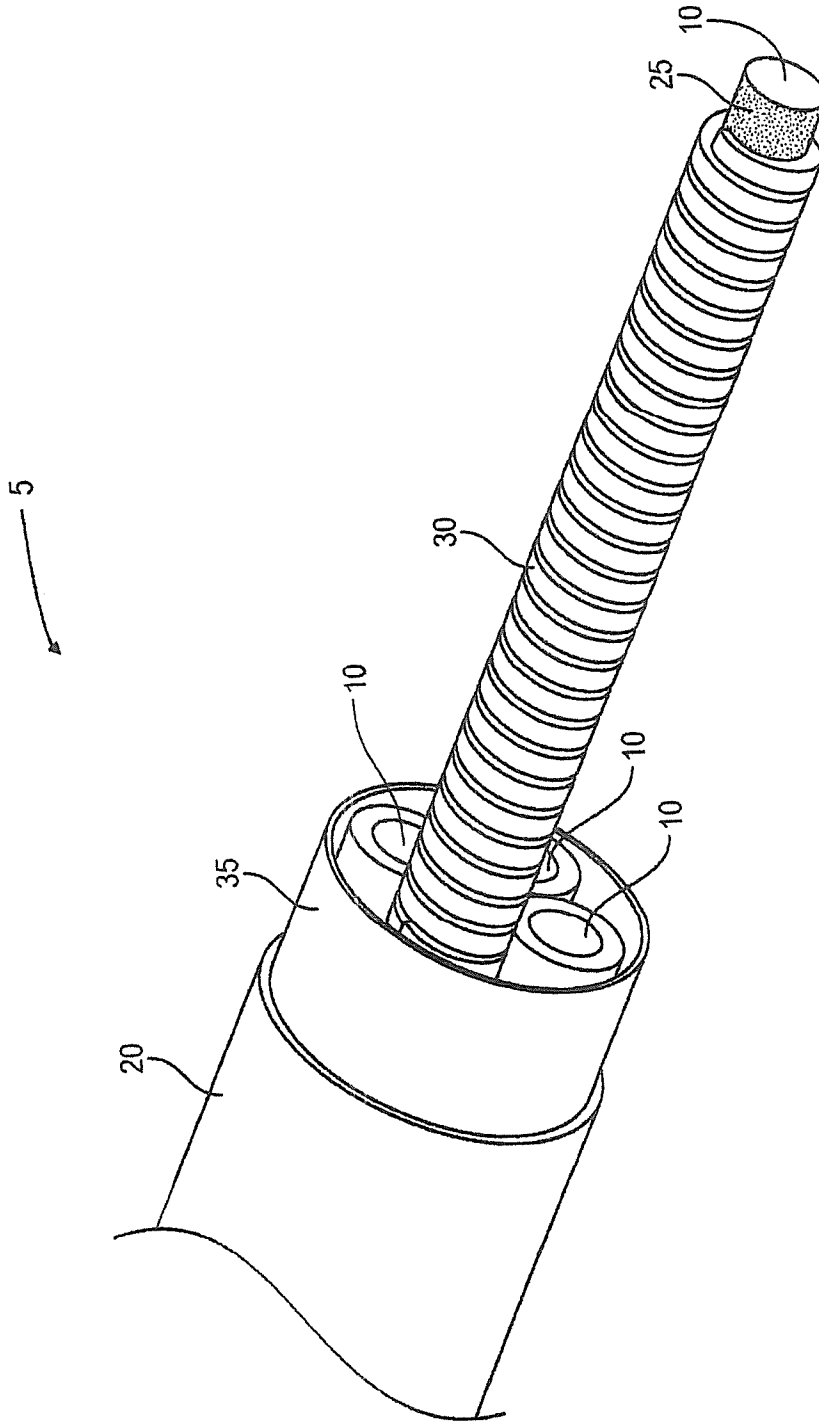

FIG. 1

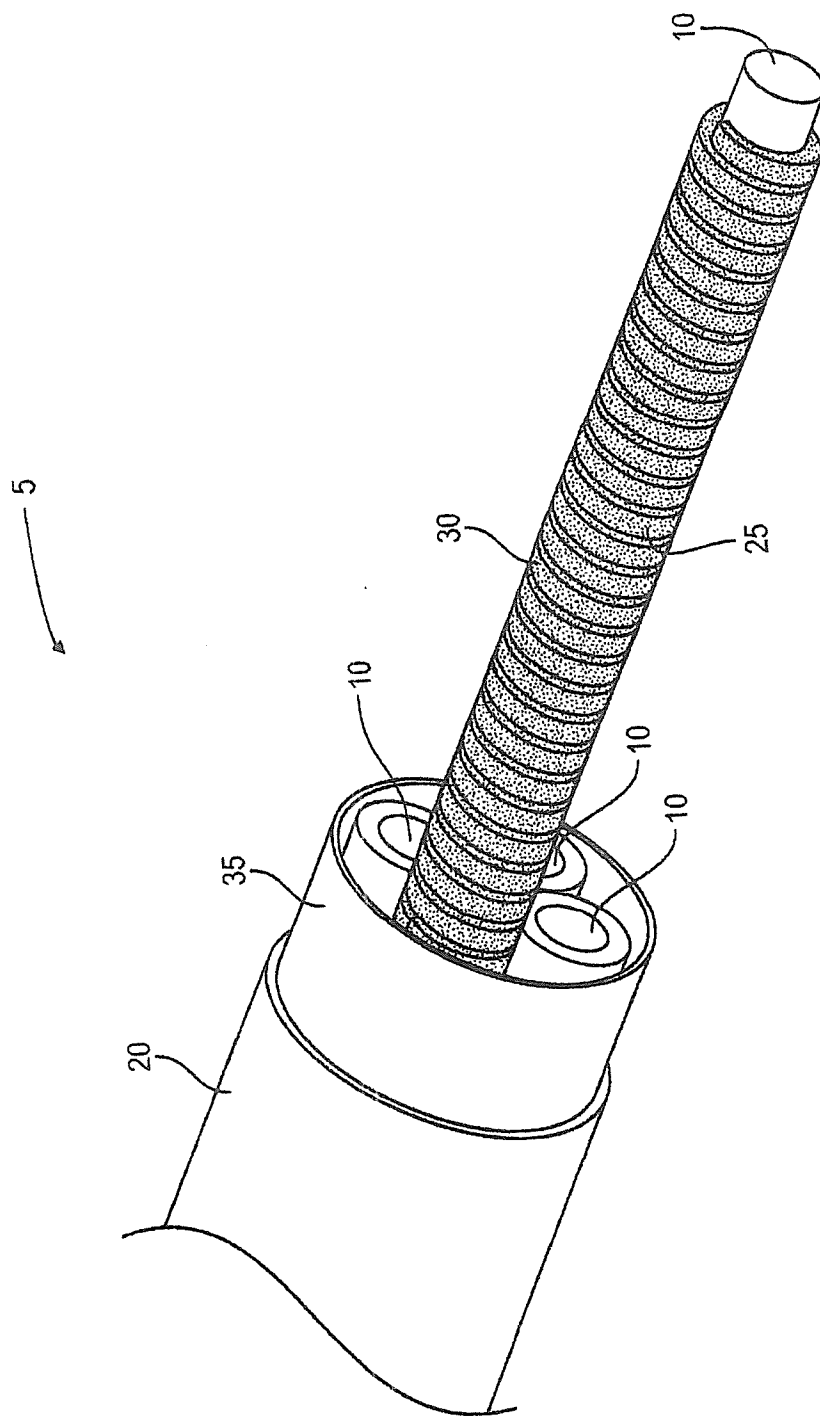

FIG. 2

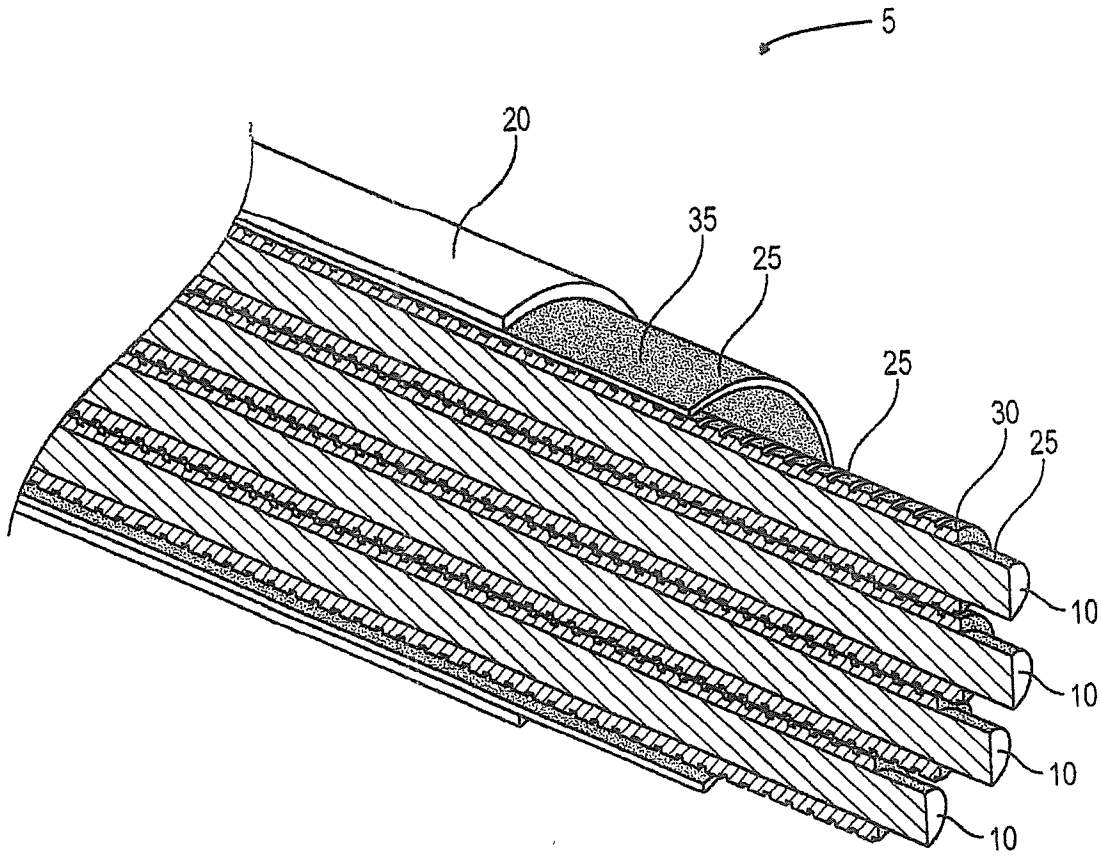

FIG. 3

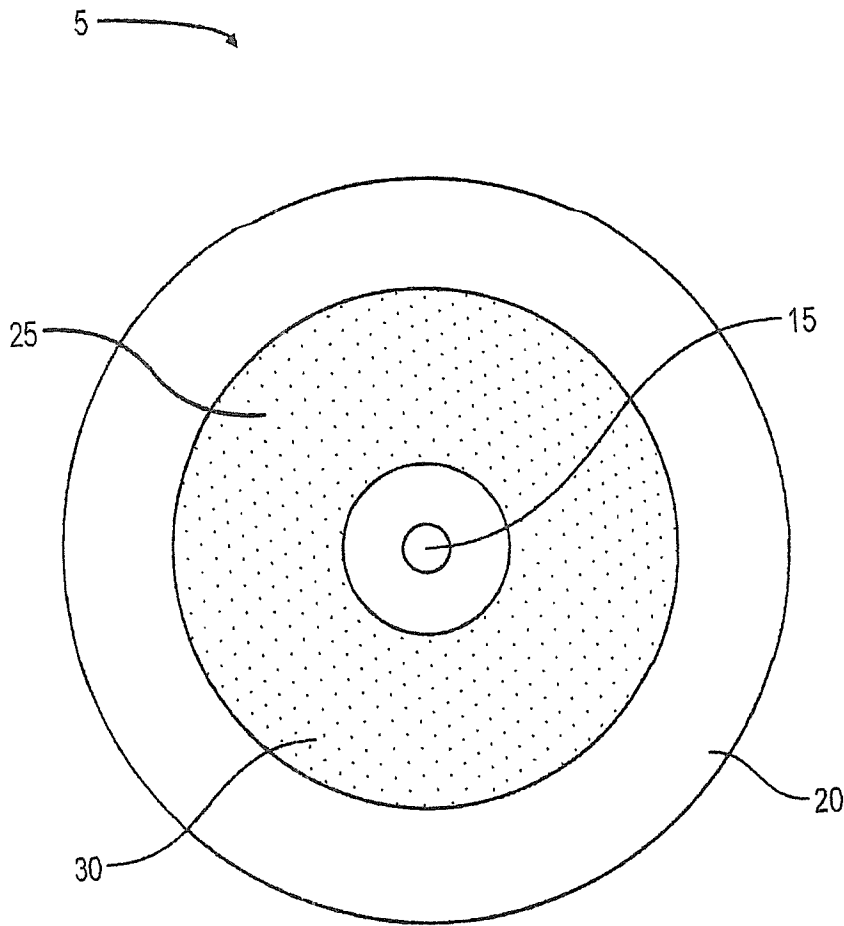

FIG. 4

U.S. Patent

Feb. 2, 2021

Sheet 5 of 7

US 10,910,129 B1

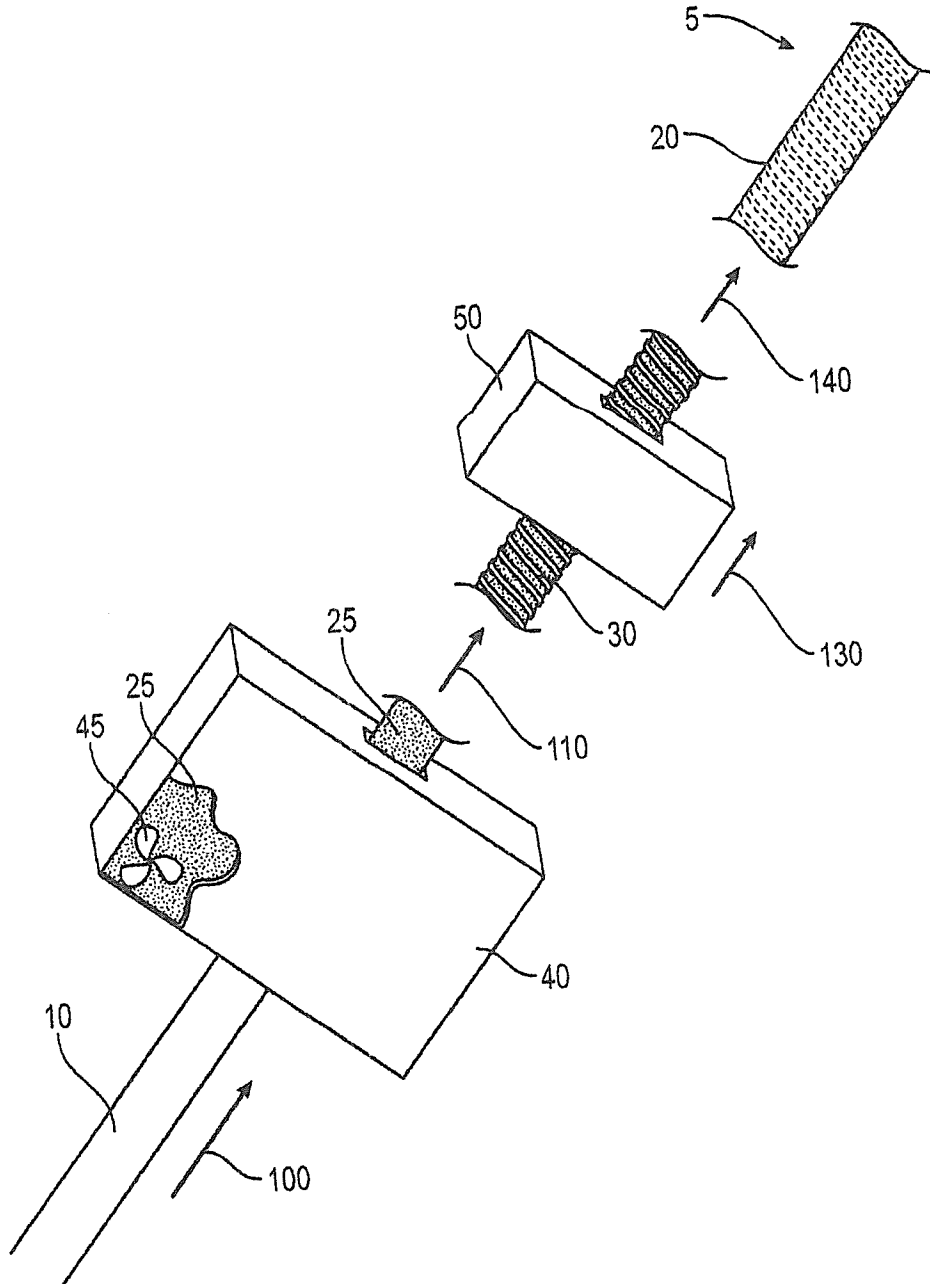

FIG. 5

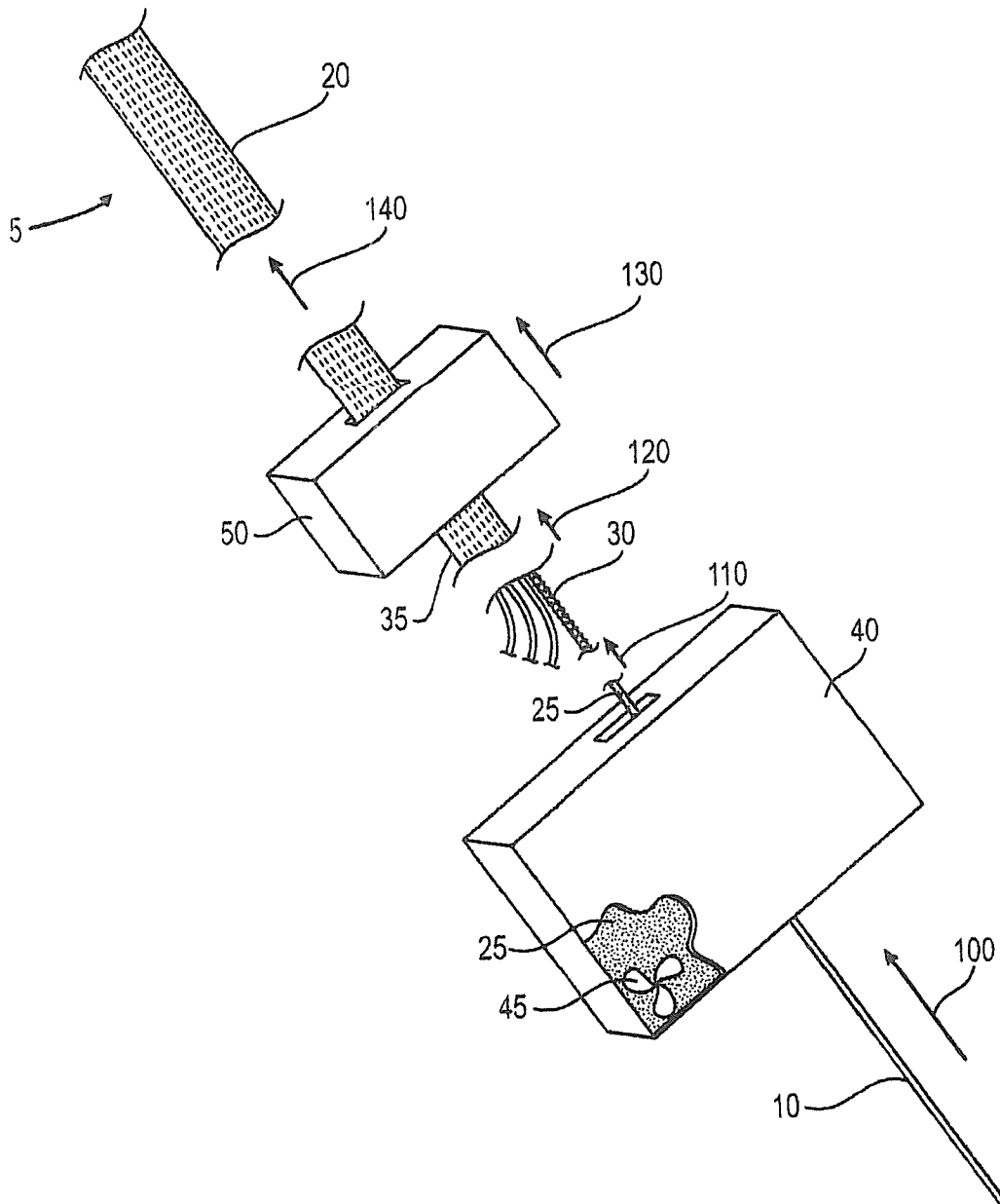

FIG. 6

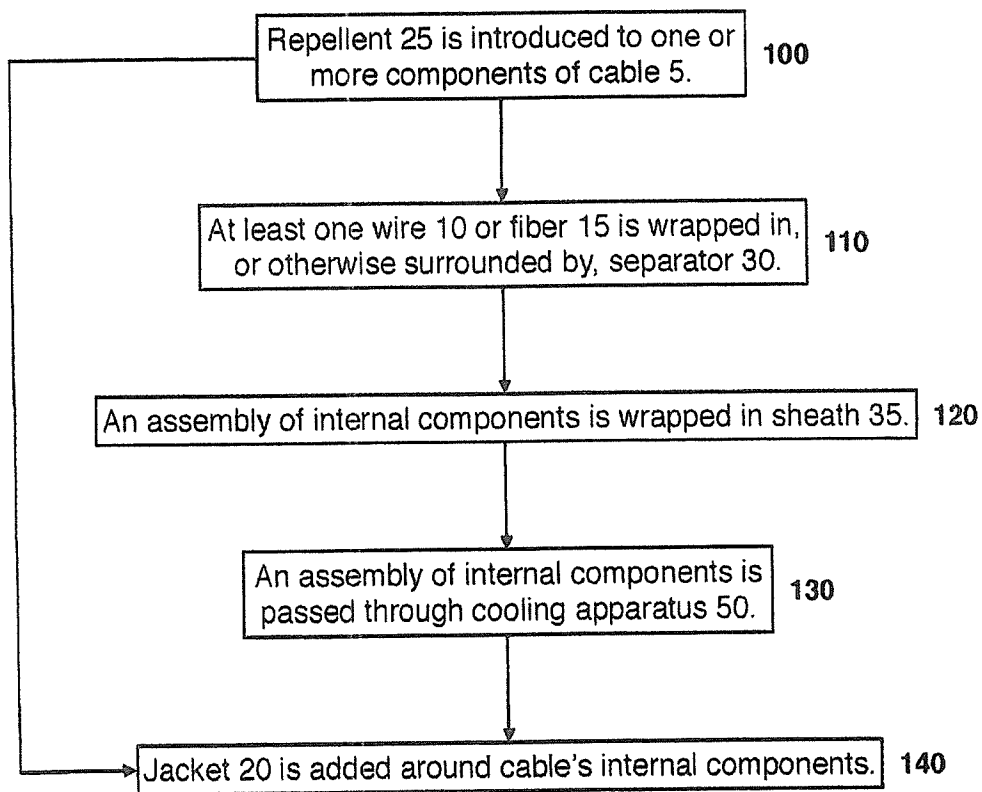

FIG. 7

US 10,910,129 B1

1

METHOD OF MANUFACTURING A RODENT
REPELLENT CABLECROSS-REFERENCE TO RELATED
APPLICATION(S)

This application is a divisional of U.S. Nonprovisional patent application Ser. No. 16/669,341 filed Oct. 30, 2019, entitled, "RODENT REPELLENT CABLE", which claims benefit of U.S. Provisional Patent Application No. 62/753,287 filed Oct. 31, 2018, entitled, "RAT REPELLENT SYSTEM", the entire disclosures of which are incorporated by reference herein.

BACKGROUND OF THE INVENTION

1. Field of Invention

The present invention relates to the field of electrical and other wiring infrastructure systems, fiber optic cable systems, and animal repellent systems. More specifically, the present invention relates to electrical cables and fiber optic cables for repelling rodents and methods of manufacturing same.

2. Description of Related Art

Rodents and similar small mammals are often found inhabiting areas also populated by people. Homes, vehicles, and other man-made structures provide opportunity for rodents to live and flourish, eventually progressing to the level of infestation. Even a single rodent can create catastrophic issues, such as spreading disease and inflicting or causing damage to structures, vehicles, and other items.

One specific example of such damage relates to electrical systems. Electrical wiring and electrical conduit generate heat, resulting from the flow of electricity therethrough. While rodents are warm blooded, they are sensitive to decreases in temperature. As a result, rodents are instinctually drawn to heat-producing wires, e.g., electrical wires, as a means to augment their body temperature with heat from the wires. Oftentimes, rodents will chew wires, causing power outages or fires, and/or presenting a dangerous potential for contact with exposed live wires. It has been postulated that a trend of transitioning from petroleum-based cable components, e.g., jacketing and primary insulation applied directly onto conductors, to more plant-based biodegradable materials, in an effort to reduce waste, has resulted in an increased incidence of rodent-inflicted wire damage, as rodents are supplementing their diets with the plant-based components as a food source.

Twenty percent (20%) of fires of undetermined origin are attributed to short circuits caused by rats chewing on the insulation of electrical wiring. Additionally, rodent-inflicted damage to car wiring systems is becoming increasingly prevalent, which, as discussed above, is attributable to automakers switching to more plant-based biodegradable materials in an effort to reduce waste. While efforts, such as jacketing wire with metal conduit, or the like, have been made to shield wire from rodents, the current materials of electrical wiring and electrical wiring insulation are not designed to repel rats.

Pest control currently involves measures taken after an infestation or problem is discovered. Companies currently offer services to remove rodents from an area through use of chemical or mechanical devices. For example, traps are commonly used to curtail rodent infestation. Typically, traps

2

are set only after a rodent is discovered. However, one noticeable issue with traps is that they are limited in the quantity of rodents they can address. Additionally, they must be reset once triggered. And, yet further, traps are typically designed to kill rodents, which many view as inhumane. While these types of treatment may be effective to address smaller-scale, existing rodent issues, they do not proactively prevent inhabitation or reoccurrence of infestation.

Poisons are also commonly used to kill rodents. Rat poison is a common and generic term for an anti-coagulant composition designed to cause fatal internal bleeding in the rodent after consumption. Just as with other treatments, such as snap-style traps that are designed to kill rodents, poisons are viewed by many to be inhumane. Further, the effect of poison compositions is indiscriminate, i.e., they have a similar detrimental (and potentially lethal) effect on humans—especially young children—or domesticated animals, if consumed.

Visual acuity of rodents is very poor. To compensate, they use their olfactory system as a means for navigation. Rodents' olfactory systems are adversely affected by certain substances. For example, a rat's olfactory system is acutely and negatively affected by menthol. Rat's olfactory cells act as receptors to atomic or molecular interaction with menthol. Exposure to menthol causes rats to experience the "freezing" sensation humans can similarly experience when exposed to concentrated menthol. This is a devastating effect for a rat, since it relies so heavily on its sense of smell for navigation.

Research studies have shown that menthol is naturally attracted, and binds, to copper to form a coating on its surface. Among other things, the menthol coating acts as a protective barrier to protect copper in acidic environments.

Based on the foregoing, clear deficiencies exist in prior art pest control systems' ability to proactively prevent inhabitation or reoccurrence of infestation or address a large number of rodents. Further, current treatments may be viewed as inhumane and present potential adverse side effects and health concerns to humans and domesticated animals. Therefore, there is a need in the art for a cable and method of manufacturing same that contains a non-toxic repellent for repelling rodents from homes, vehicles, and other structures, items, or areas containing wire or cable.

SUMMARY OF THE INVENTION

A rodent repellent cable includes, but is not limited to, an outer jacket, a transmission means for facilitating transmission of electrical current or data, and a repellent bonded to at least one component of the cable. The transmission means extends longitudinally through an interior of the cable, the interior being defined by an interior wall of the jacket.

In an embodiment, a method of manufacturing the rodent repellent cable, includes electrostatically bonding a repellent to one or more components of the cable and adding the jacket around one or more internal components of the cable, such that the one or more internal components are disposed within the interior of the cable. The repellent is preferably an olfactory stimulant, such as menthol, configured to repel rodents.

In some embodiments, prior to adding the jacket around the one or more internal components of the cable, the method includes wrapping, enclosing, or otherwise surrounding one or more of the transmission means with a separator. In various embodiments, the separator is constructed of a non-conductive material, such as paper or aramid fiber/yarn.

US 10,910,129 B1

3

In some embodiments, prior to adding the jacket around one or more internal components of the cable, the method includes wrapping, enclosing, or otherwise surrounding an assembly of internal cable components with a sheath. In various embodiments, the sheath is preferably, but not necessarily, constructed of a non-conductive material, such as paper or aramid fiber/yarn.

In some embodiments, prior to adding the jacket around one or more internal components of the cable, the method includes passing an assembly of internal cable components through a cooling apparatus to cool the assembly to a pre-determined temperature.

The foregoing, and other features and advantages of the invention, will be apparent from the following, more particular description of the preferred embodiments of the invention, the accompanying drawings, and the claims.

BRIEF DESCRIPTION OF THE DRAWINGS

For a more complete understanding of the present invention, the objects and advantages thereof, reference is now made to the ensuing descriptions taken in connection with the accompanying drawings briefly described as follows.

FIG. 1 illustrates a partial perspective cutaway view of the rodent repellent cable, according to an embodiment of the present invention;

FIG. 2 illustrates a partial perspective cutaway view of the rodent repellent cable, according to an embodiment of the present invention;

FIG. 3 illustrates a partial perspective cutaway view of the rodent repellent cable, according to an embodiment of the present invention;

FIG. 4 illustrates a cross-sectional view of the rodent repellent cable, according to an embodiment of the present invention;

FIG. 5 illustrates a system for manufacturing the rodent repellent cable, according to an embodiment of the present invention;

FIG. 6 illustrates a system for manufacturing the rodent repellent cable, according to an embodiment of the present invention; and

FIG. 7 is a flow chart showing a method of manufacturing the rodent repellent cable, according to an embodiment of the present invention.

DETAILED DESCRIPTION OF PREFERRED EMBODIMENTS

Preferred embodiments of the present invention and their advantages may be understood by referring to FIGS. 1-7, wherein like reference numerals refer to like elements.

With reference to FIGS. 1-4, rodent repellent cable 5 includes one or more wires 10 or one or more fibers 15 disposed within an interior portion of cable 5 defined by the inner wall of outer protective jacket 20. Wire 10 may be any conductive wire for facilitating the transmission of electrical power, electrical signals, telecommunication signals, etc. Additionally, one or more of wires 10 may be insulated. Fibers 15 may be any non-conductive material, e.g., glass (silica) or plastic, for facilitating the transmission of data for telecommunications, computer networking, etc. Repellent 25 is adsorbed, adhered, or otherwise bonded to at least one component of cable 5. Repellent 25 is preferably any substance that repels rodents, based on a negative olfactory stimulus when the rodents are subjected to repellent 25. Connectors (not shown) may be coupled to the ends of cable 5 for facilitating connection to systems, devices, etc.

4

In an embodiment, at least one wire 10 or fiber 15 is wrapped in, or otherwise surrounded by, one or more separators 30. Separator 30 is constructed of a non-conductive material, such as paper or aramid fiber/yarn, and may be used for a number of reasons, including, but not limited to, insulating the wrapped wire 10 or fiber 15 from other components within jacket 20 and/or providing structural support, protection, and tensile strength to cable 5.

Separator 30 may be embodied in a number of ways. For example, separator 30 may be a tubular member for housing fibers 15. As another example, separator 30 may be one or more strips of material that is folded, rolled, or bundled lengthwise to surround wire 10, fiber 15, or other component surrounding wire 10 or fiber 15. As yet another example, separator 30 may be a spiral wrapping, whereby, in use, separator 30 is wrapped around wire 10 or fiber 15 in a spiral fashion.

In an embodiment, sheath 35 is disposed within jacket 20 and surrounds an assembly of cable's internal components, e.g., wires 10 or fibers 15 and, optionally, separator 30. Sheath 35 is preferably, but not necessarily, constructed of a non-conductive material, such as paper or aramid fiber/yarn.

In an embodiment, repellent 25 is menthol. Menthol is a non-toxic substance, i.e., it is not known to be lethal, or otherwise detrimental to the health and safety of humans and/or animals. This is important, as it would ensure that the pests are not harmed, killed, or otherwise dealt with in an inhumane manner. Additionally, it would ensure the safety of young children, domesticated animals and individuals charged with the removal, disposal, and/or recycling of the cable at the end of its service life.

FIGS. 5-7 show example systems and methods of manufacturing the rodent repellent cable. At step 100, repellent 25 is introduced to one or more components of cable 5. This is accomplished a number of ways, including, but not limited to: passing the components through vaporized repellent 25; spraying liquid repellent 25 onto the components or immersing the components in liquid repellent 25 and allowing the components to dry; or passing the components through a suspension of repellent particulate 25, whereby repellent 25 binds to the components through the assistance of an additive, e.g., an adhesive, and/or an electrostatic bond. Repellent 25 may be prepared in solution through generally understood means such as dissolving solid repellent 25, e.g., menthol in crystalline form, in solvents, e.g., propylene glycol, or converting solid repellent 25 into a liquid by heating solid repellent 25. Following is a non-exhaustive list of examples of the process of binding repellent 25 to the components of cable 5.

Example 1

Agitator 40 has one or more air handlers 45, such as fans or air hoses (the hoses being connected to pressurized air sources, e.g., an air compressor), for circulating air within agitator 40. Repellent 25 is added to agitator 40, whereby the circulating air is configured to maintain suspension of repellent 25 within agitator 40. As wire 10 is passed into and through agitator 40, suspended repellent 25 binds to wire 10. Binding of dry repellent to wire 10 may be naturally facilitated, e.g., by static electricity. The binding effect may be enhanced by addition of an electrical charge to wire 10. In some cases, repellent 25 will naturally adsorb to wire 10. For example, as discussed above, when exposed to copper, menthol naturally adsorbs, i.e., binds, to the copper to form a coating thereon.

US 10,910,129 B1

5

Example 2

Separator 30 and/or sheath 35 is passed through, or positioned within, agitator 40. Prior to entering agitator 40 or while in agitator 40, separator 30 and/or sheath 35 may be moistened with a solvent, e.g., with propylene glycol, or prepped with an adhesive or other bonding agent to facilitate attachment of atomized, suspended repellent 25 within agitator 40. A sprayer or other means (not shown) may be employed to moisten or prep separator 30 and/or sheath 35 with adhesive or other bonding agent.

Example 3

An electrical current may be applied to wire 10 and repellent 25 to create opposing electrical charges to promote bonding between wire 10 and repellent 25. As seen in electroplating or powder coating, the opposing electrical charges create an attraction between wire 10 and repellent 25, whereby repellent 25 binds to wire 10 to form a coating thereon.

Example 4

Repellent 25 may be vaporized, whereby one or more cable components are passed through the resulting vapor. As the vapor condenses and dries, repellent 25 adsorbs, adheres, or otherwise binds to the components.

Optionally, at step 110, at least one wire 10, fiber 15, or other component surrounding at least one wire 10 or fiber 15 is wrapped in, or otherwise surrounded by, separator 30. In an embodiment, wire 10 wrapped in separator 30 is an uninsulated wire 10, e.g., a bare copper wire.

Optionally, at step 120, an assembly of internal components, including, but not limited to, wires 10 or fibers 15 and, optionally, separator 30, is wrapped in sheath 35.

Optionally, at step 130, the assembly of internal components, with or without sheath 35, is passed through cooling apparatus 50 to cool the components to a pre-determined temperature. This is done to avoid loss of repellent 25, due to vaporization during the jacketing process. Hence, the pre-determined temperature is calculated based on the boiling point, i.e., vaporization temperature, of repellent 25, the initial temperature of repellent 25, the specific heat capacity of repellent 25, the jacketing temperature, and the length of time repellent 25 is exposed to the jacketing temperature. If the boiling point of repellent 25 is higher than the temperature of the jacketing process, use of cooling apparatus 50 is not necessary. If, however, the boiling point of repellent 25 is lower than the temperature of the jacketing process, cooling apparatus 50 may be used to lower the temperature of repellent 25 to a pre-determined temperature such that the temperature of repellent 25 does not reach the point of vaporization during the jacketing process.

At step 140, jacket 20 is added, whereby the cable's internal component(s), including, but not limited to, wire(s) 10 or fiber(s) 15, and, optionally, separator 30 and/or sheath 35, are disposed within cable's interior. One skilled in the art would understand and appreciate that application of jacket 20 could be accomplished in a number of ways known in the art.

While the foregoing method is described and shown in a numerical, step-wise order, it should be understood that the steps are not limited to any specific order. Additionally, some steps may overlap in time, i.e., they may be carried out simultaneously, with other steps.

6

The invention has been described herein using specific embodiments for the purposes of illustration only. It will be readily apparent to one of ordinary skill in the art, however, that the principles of the invention can be embodied in other ways. Likewise, it will be readily apparent that the features, functions, and/or elements of the present invention disclosed herein can be used in any combination to produce various embodiments of the present invention. Therefore, the invention should not be regarded as being limited in scope to the specific embodiments disclosed herein, but instead as being fully commensurate in scope with the following claims.

We claim:

1. A method of manufacturing a rodent repellent cable, the method comprising:
 - electrostatically bonding a repellent to one or more components of the cable, wherein the repellent is an olfactory stimulant configured to repel rodents; and
 - adding a jacket around one or more internal components of the cable, such that the one or more internal components are disposed within an interior of the cable, the interior defined by an interior wall of the jacket.
2. The method of claim 1, wherein the repellent is menthol.
3. The method of claim 1, wherein, prior to adding the jacket around the one or more internal components of the cable, the method further comprises:
 - adding a separator around a transmission means, the transmission means being disposed within the interior of the cable.
4. The cable of claim 3, wherein the separator is a tubular member.
5. The cable of claim 3, wherein the separator comprises one or more strips of material.
6. The method of claim 3, wherein the separator is spirally-wrapped around the transmission means.
7. The method of claim 3, wherein the transmission means comprises one or more conductive wires, wherein the separator is added around at least one of the one or more conductive wires.
8. The method of claim 7, wherein the one or more conductive wires comprise a copper wire.
9. The method of claim 8, wherein the repellent is menthol.
10. The method of claim 7, wherein the separator is made of paper.
11. The method of claim 3, wherein the transmission means comprises one or more optical fibers, wherein the separator is added around at least one of the one or more optical fibers.
12. The method of claim 11, wherein the separator is made of aramid yarn.
13. The method of claim 11, wherein the repellent is menthol.
14. The method of claim 1, wherein, prior to adding the jacket around the one or more internal components of the cable, the method further comprises:
 - wrapping an assembly of internal cable components in a sheath.
15. The method of claim 14, wherein the sheath is made of paper.
16. The method of claim 14, wherein the sheath is made of aramid yarn.
17. The method of claim 1, wherein, prior to adding the jacket around the one or more internal components of the cable, the method further comprises:

US 10,910,129 B1

7

passing an assembly of internal cable components through a cooling apparatus to cool the assembly to a pre-determined temperature.

* * * * *

8